

## Data Sheet

### INTRO.PDF

4 Pages

Last Revised 26/06/09

## Getting Started

Thank you for purchasing a MicroRWD evaluation kit. The aim of this kit is to allow you to evaluate all the features of the particular RFID (**R**adio **F**requency **I**Dentification) transponder type and the capabilities of the MicroRWD reader module. This is undoubtedly one of the smallest and lowest cost solutions for RFID read/write communication for the latest 125 kHz and 13.56 MHz contactless cards and tag types. The Windows software supplied on CDROM allows the evaluation board to be connected to a PC via a serial cable (or optional USB) and the simple interface will allow you to immediately communicate with the MicroRWD reader and the supplied tag/card. The application software is designed to be simple to use and provides the easiest route to understanding this powerful new technology. Please follow the steps highlighted below to ensure that you can begin evaluation of the system immediately:

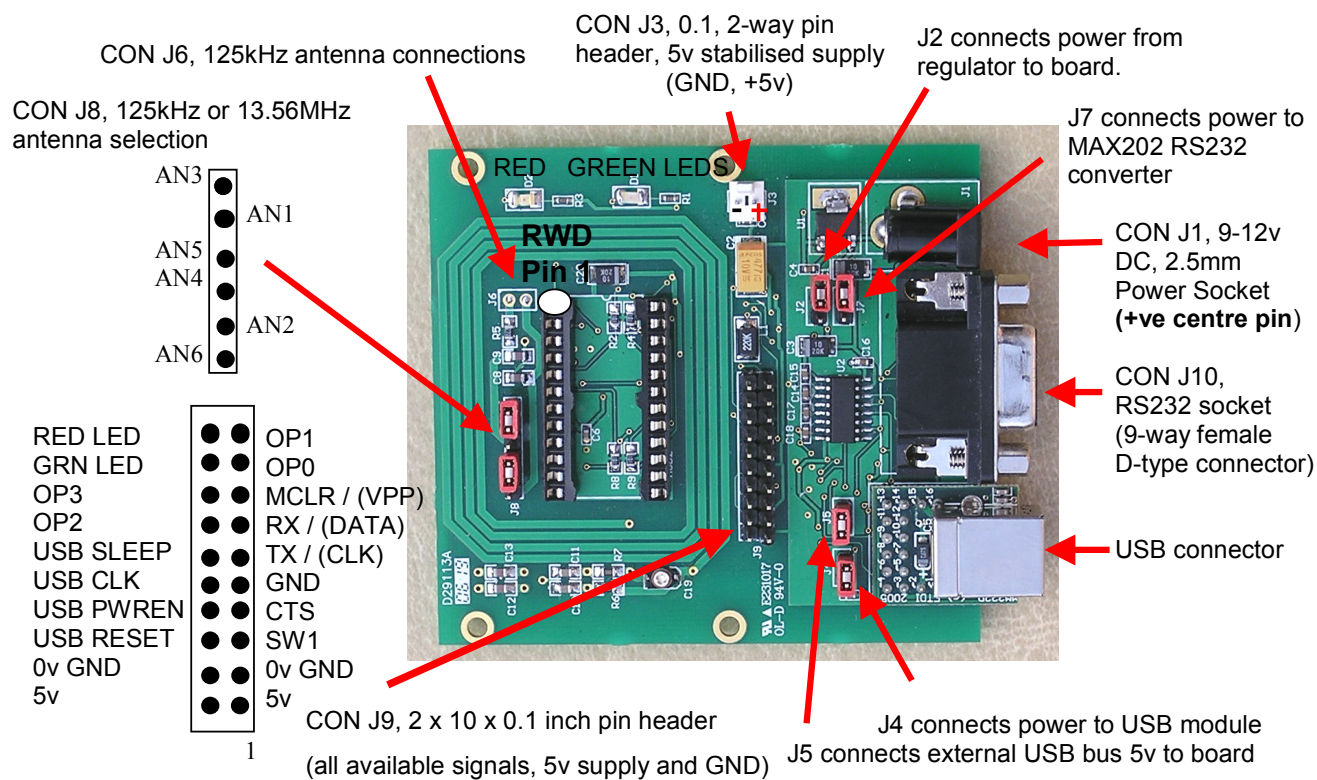

### Universal RFID base board with RS232 and optional USB interface.

Please refer to UNI\_RS232\_USB.PDF data sheet on the CDROM or website (<http://www.ibtechnology.co.uk/>) for full description of connections, links and features of the Universal RFID base board.

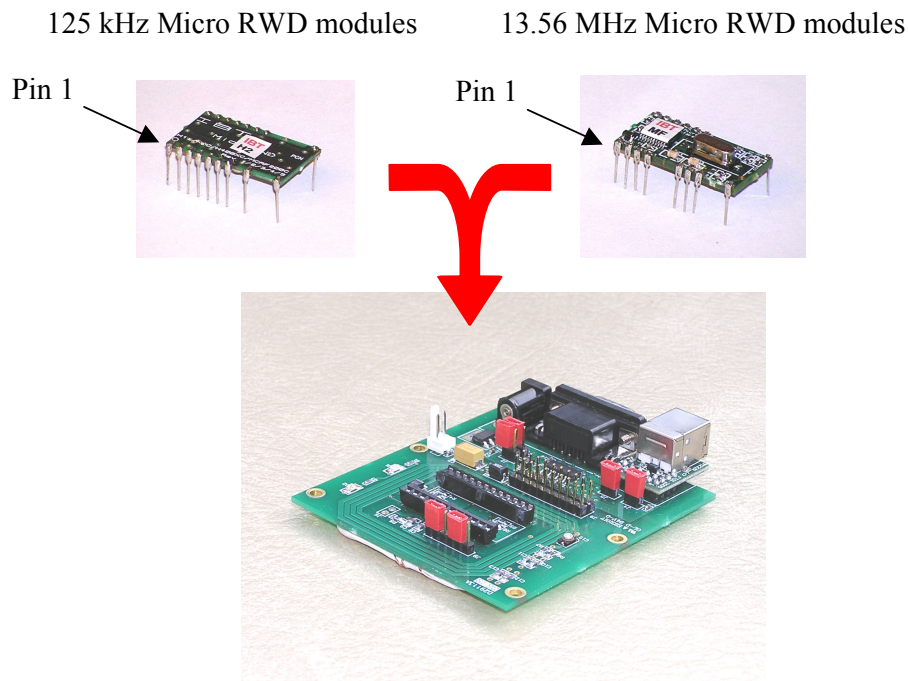

- 1) Unpack the items in the evaluation kit and identify the following items:
  - a) MicroRWD module.
  - b) Universal RFID base board (with RS232 and optional USB interface).
  - c) RS232 serial cable for connecting to a PC.
  - d) Sample 700  $\mu\text{H}$  antenna coil (depending on whether 125kHz or 13.56MHz kit).  
The 1 $\mu\text{H}$  antenna for use with 13.56MHz modules is a PCB track on the Universal RFID base board.
  - e) Sample contactless card/tag according to the kit type.
  - f) “Getting Started and Introduction” data sheets.
  - g) Data sheets and Windows application software on CDROM (also available on website: [www.ibtechnology.co.uk](http://www.ibtechnology.co.uk))
- 2) Carefully plug the MicroRWD module into the 24 pin socket on the Universal base board ensuring that pin 1 is aligned correctly and that the pins are not bent or damaged.
- 3) If the Evaluation kit is for the 125kHz MicroRWD modules then solder the two connecting wires of the 700 $\mu\text{H}$  antenna coil to the J6 pads as in the diagram.
- 4) Select the appropriate 125 kHz or on-board 13.56 MHz antenna type by fitting links to 6-pin header J8 according to the diagram below:

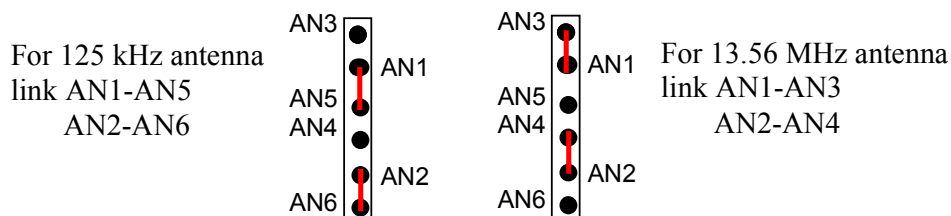

- 5) Fit links to J2 and J7 to connect the on-board 5-volt regulator and provide power to the on-board RS232 converter (Also fit links to J4 and J5 if the optional MM232R USB interface is fitted).

Note that depending on the Kit supplied, the Universal RFID base board may be supplied with the MicroRWD module and 700µH antenna coil already fitted.

**If in doubt, then links J2, J4, J5, J7 can all be fitted and left permanently connected.**

- 6) Connect a 9-12 volt DC power supply to the J1 power connector.

OR

Connect a 5-volt DC REGULATED supply to the J3 power connector ensuring that the polarity is correct (see diagram over page).

Note that the average current consumption of the Universal RFID base-board with the MicroRWD fitted is less than 100mA. However we recommend that the Power supply used is of good quality, reasonably noise-free and capable of supplying at least 250mA.

OR

If the “FTDI MM232R USB module” is fitted, connect the Universal RFID base-board to a PC using a standard USB cable. Note that the USB cable provides communication and power so no external power supply is required in this case.

- 7) Connect the RS232 serial cable to your PC communication port (9 way to 9 way cable, connected straight through, pin to pin) or use the USB cable if the USB module is fitted (see above).
- 8) If using the “FTDI MM232R USB” interface then first install the latest version of the FTDI VCP (Virtual Com Port) USB driver. This can be downloaded from:  
<http://www.ftdichip.com/Drivers/CDM/CDM%202.04.16.exe>
- 9) Install the MicroRWD Windows application software located in the CDRom \Win32 directory (for the particular tag/card type) by running the SETUP program and following the on-screen instructions in the usual way. The programs have been written using the Borland C++Builder software tools and have been tested on all current Win32 platforms including Windows 95/98, 2000/NT, XP and Vista.
- 10) Double click on the MicroRWD program icon and once the application is running pull-down the COM PORT option and select the COM PORT that you are using

Your system is now ready for use and should respond when the card or tag is placed in the RF field. The printed documents and data sheets on the CDRom describe how the system works and the basic operational commands. Further information can be found on IB Technology’s website: <http://www.ibtechnology.co.uk/> or alternatively please send an email to: [support@ibtechnology.co.uk](mailto:support@ibtechnology.co.uk)

The aim of this Evaluation kit is to stimulate new ideas and applications where this technology can be used and to allow rapid prototyping of end products. The MicroRWD modules are complete RFID read/write units with easy to use commands and interfaces. The UNI\_RS232\_USB.PDF data sheet and all other data sheets / application notes explain the operation of the modules and the serial command protocols and describe typical application circuit diagrams.

Ultimately your application design, the antenna size, positioning and characteristics will influence the approvals for your final product although every possible design technique has been employed to ensure that the MicroRWD module is as efficient and EMC compliant as possible (approvals documentation and product description data is provided).

The MicroRWD module version that you are evaluating represents the standard product for that particular RF transponder type, with the most likely features required for evaluation. Please note that there are many other pin-compatible versions of the MicroRWD supporting other RF transponder types offering different memory sizes and levels of security as well as various connectivity options such as Weigand and Clock/Data (Mag Stripe) output in addition to the standard RS232 option. Please contact us at our email address for more information.

**No responsibility is taken for the method of integration or final use of MicroRWD**

More information on the Micro RWD and other products can be found at the Internet web site:

**<http://www.ibtechnology.co.uk>**

Or alternatively contact IB Technology by email at:

**[sales@ibtechnology.co.uk](mailto:sales@ibtechnology.co.uk)**